

Chamber step

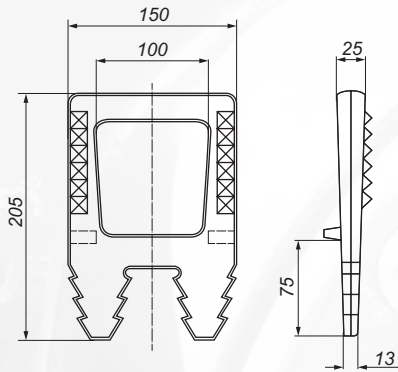

Chamber step 1211 for hammering

Coating: bitumen paint
Material: cast iron EN-GJL-250, PN-EN 1561:2000
Weight: 2,00 kg

Norm: PN-EN 13101

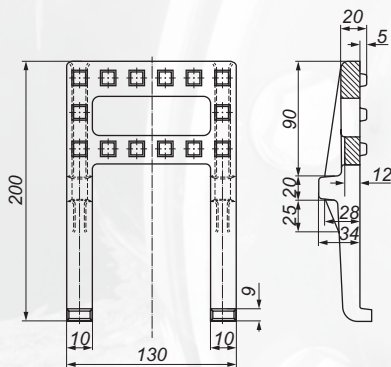

Chamber step medium for embedding

Coating: bitumen paint
Material: cast iron EN-GJL-250, PN-EN 1561:2000
Weight: 1,60 kg

Norm: PN-EN 13101

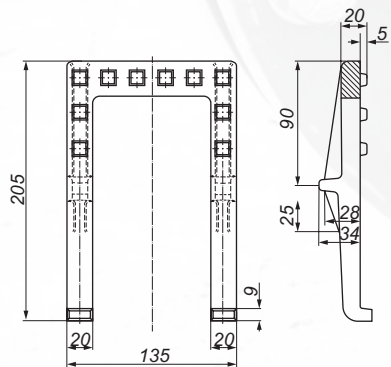

Chamber step (ductile iron) for embedding

Coating: bitumen paint
Material: ductile iron PN-GJS-500-7, PN-EN 1563:2000
Weight: 1,50 kg

Norm: PN-EN 13101

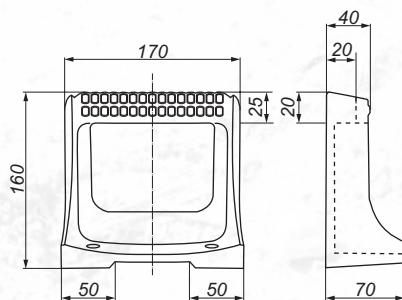

Chamber step 1212G for screwing

Coating: bitumen paint
Material: cast iron EN-GJL-250, PN-EN 1561:2000
Weight: 2,60 kg

Norm: PN-EN 13101