

Flanged tee T PN 10 and ductile iron PN 10/16

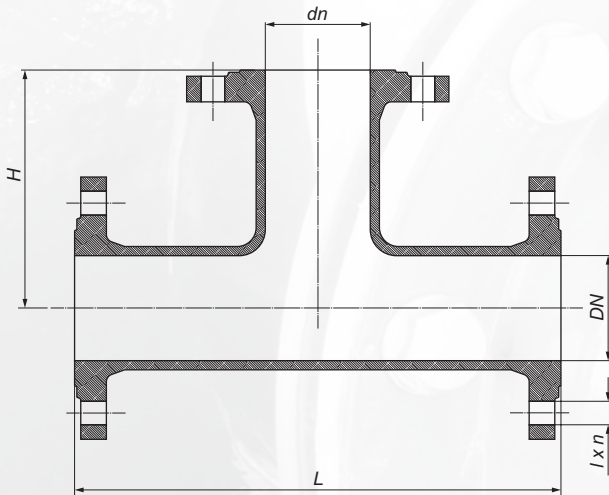

It is used to branch and mount fittings on the water supply network.

Coating: bitumen paint, epoxy paint 250-360 μm
Material: cast iron EN-GJL-250, PN-EN 1561:2000
Flange connection: PN-EN 1092-2:1999
Nominal pressure: 1,0 MPa; PN 10

DN	dn	L	H	l	n	Weight
50	50	300	150	18	4	11,70
80	50	320	160	18	4(8)/4	16,30
	80	320	165	18	4(8)	17,00
100	50	360	170	18	8/4	19,40
	80	360	175	18	8/4(8)	20,40
	100	360	180	18	8	21,10
150	80	440	205	22	8/4(8)	34,00
	100	440	210	22	8	36,00
200	150	440	220	22	8	40,60
	80	520	235	22	8/4(8)	52,00
200	100	520	240	22	8	53,00
	150	520	250	22	8	55,00
	200	520	260	22	8	61,00

Coating: epoxy paint 250-360 μm
Material: ductile iron, EN-GJS-500-7, PN-EN 1563:2000
Flange connection: PN-EN 1092-2:1999
Nominal pressure: 1,0/1,6 MPa; PN 10/16

DN	dn	L	H	l	n	Weight
50	50	300	150	18	4	11,50
65	65	330	165	18	4	12,50
80	50	310	160	18	8/4	14,20
	65	330	165	18	8/4	14,50
	80	330	165	18	8	15,60
100	50	320	165	18	8/4	18,40
	65	320	165	18	8/4	18,60
	80	360	175	18	8	19,00
	100	360	180	18	8	19,30
125	80	400	190	18	8	23,10
	100	400	195	18	8	23,50
	125	400	195	18	8	23,90
150	50	440	205	22	8/4	29,00
	65	440	205	22	8/4	30,00
	80	440	205	22	8	30,50
	100	440	210	22	8	32,50
	125	440	210	22	8	33,00
	150	440	220	22	8	34,00
200	80	520	235	22	8(12)/8	45,00
	100	520	240	22	8(12)/8	46,00
	150	520	250	22	8(12)/8	48,00
	200	520	260	22	8(12)	49,00
250	80	700	265	22(26)	12/8	65,00
	100	700	275	22(26)	12/8	69,00
	150	700	280	22(26)	12/8	70,00
	200	700	325	22(26)	12/8(12)	80,00
	250	700	350	22(26)	12	89,00
300	80	800	295	22(26)	12/8	93,00
	100	800	300	22(26)	12/8	97,00
	150	800	310	22(26)	12/8	98,00
	200	800	330	22(26)	12/8(12)	105,00
	250	800	350	22(26)	12	116,00
	300	800	400	22(26)	12	125,00