

Overground hydrant double protected, breakable DN 100 PN 10 and ductile iron PN 10/16

No.	Description	Pcs.	Material
1.	Protection cap	1	Polyethylene
2.	Spacer ring	1	EN-GJL-250/EN-GJS-500-7
3.	Chamber	1	EN-GJL-250/EN-GJS-500-7
4.	Piston	1	EN-GJS-500-7/EPDM/NBR
5.	Gasket	3	EPDM/NBR
6.	Pipe	1	Steel PN-EN 10088-3:2015 Steel PN-EN 10224:2003
7.	Rivet	2	Steel St 2/Steel C1006
8.	Pipe	1	Steel PN-EN 10088-3:2015 Steel PN-EN 10224:2003 Ductile iron PN-EN 1563:2012
9.	Nut casing	1	EN-GJS-500-7
10.	Head	1	EN-GJL-250/EN-GJS-500-7
11.	Nut	1	Brass MO59
12.	Stporz coupling	2	Aluminum AK11
13.	Cover gasket	2	EPDM/NBR
14.	Cover	2	EN-GJL-250/EN-GJS-500-7/ AK11/Polyethylene
15.	Cord	1	Steel
16.	Bearing	2	Tarnamid
17.	O-ring	3	EPDM/NBR
18.	O-ring	1	EPDM/NBR
19.	Choke	1	Brass MO59
20.	Spindle	1	Stainless steel 2H13
21.	Allen screw	1	Galvanized steel 8.8 class/ Stainless steel A2
22.	Knob	1	EN-GJL-250/EN-GJS-500-7
23.	Storz coupling gasket	2	EPDM/NBR
24.	Storz coupling DN 100	1	Aluminum AK11
25.	Storz coupling gasket DN 100	1	EN-GJL-250/EN-GJS-500-7/ AK11/Polyethylene
26.	Reducer	1	EN-GJS-500-7
27.	Screw, pad, nut	4	Galvanized steel 8.8 class/ Stainless steel A2
28.	O-ring	1	EPDM/NBR
29.	Upper flange	1	EN-GJS-500-7
30.	Lower flange	1	EN-GJS-500-7
31.	Middle spindle nut	1	Stainless steel 2H13/ Brass MO59
32.	Middle spindle	1	Stainless steel 2H13
33.	Clutch	1	EN-GJL-250/EN-GJS-500-7
34.	Ball pusher	1	Stainless steel 2H13
35.	O-ring	2	EPDM/NBR
36.	Screw, pad	4	Galvanized steel 8.8 class/ Stainless steel A2
37.	Ball	1	EPDM/NBR
38.	Ball chamber	1	EN-GJS-500-7

Coating: epoxy paint UV resisted, 250-360 μm
 Flange connection: PN-EN 1092-2:1999
 Nominal pressure: 1,0/1,6 MPa, PN 10/16

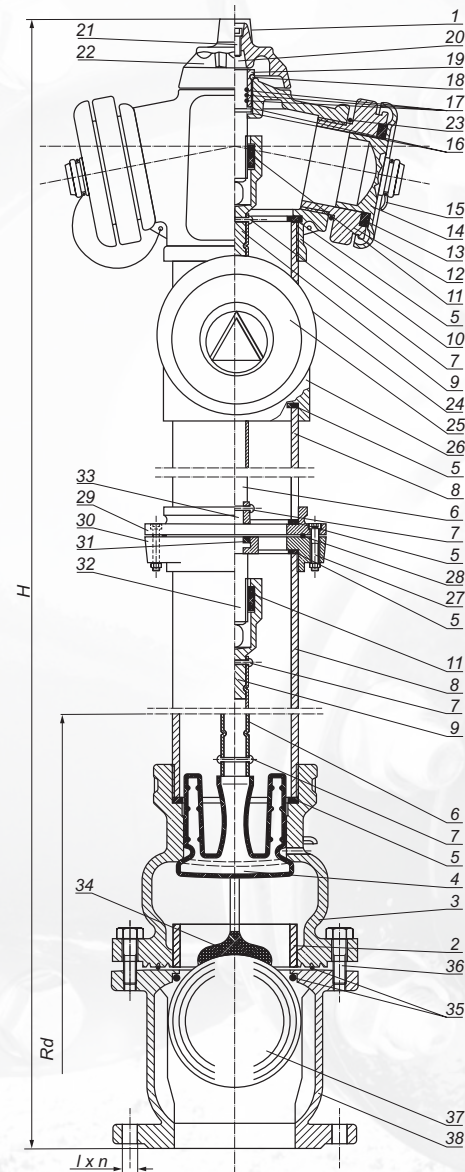

Overground hydrant - double protected; breakable with a nominal diameter of 100 mm for pressure 1,0 or 1,6 MPa with an automatic drainage device in the lower chamber. Intended for drawing water from a general-purpose pipeline with a nominal diameter of 100 mm, water at a temperature of up to 40°C and a pressure of up to 1,0 or 1,6 MPa. Equipped with a ball protection.

DN	Size	H	Rd	l	n	Weight
100	A	1900	1250	18	8	51,00
	B	2150	1500	18	8	54,00
	C	2450	1800	18	8	56,00
	X	as per order				