

Underground hydrant double protected DN 80 PN 10 and ductile iron PN 10/16

No.	Description	Pcs.	Material
1.	Spacer ring	1	EN-GJL-250/EN-GJS-500-7
2.	Chamber	1	EN-GJL-250/EN-GJS-500-7
3.	Piston	1	EN-GJS-500-7/EPDM/NBR
4.	Gasket	2	EPDM/NBR
5.	Pipe	1	Steel PN-EN 10088-3:2015 Steel PN-EN 10224:2003
6.	Rivet	2	Steel St 2/Steel C1006
7.	Pipe	1	Steel PN-EN 10088-3:2015 Steel PN-EN 10224:2003 Ductile iron PN-EN 1563:2012
8.	Nut casing	1	EN-GJS-500-7
9.	Nut	1	Brass MO59
10.	Spindle	1	Stainless steel 2H13
11.	Head	1	EN-GJL-250/EN-GJS-500-7
12.	Choke	1	Brass MO59
13.	Bearing	2	Tarnamid, steel
14.	O-ring	3	EPDM/NBR
15.	Protection ring	1	EPDM/NBR
16.	O-ring	1	EPDM/NBR
17.	Rivet	1	Steel St 2
18.	Knob	1	EN-GJL-250/EN-GJS-500-7
19.	Gasket	1	EPDM/NBR
20.	Hook	1	EN-GJS-500-7
21.	Protection cap	1	EPDM/NBR
22.	Cord	1	Steel
23.	Screw, pad, nut	2	Galvanized steel 8.8 class/ Stainless steel A2/A4
24.	Ball pusher	1	Stainless steel 2H13
25.	O-ring	2	EPDM/NBR
26.	Screw, pad	4	Galvanized steel 8.8 class/ Stainless steel A2
27.	Ball	1	EPDM/NBR
28.	Ball chamber	1	EN-GJS-500-7

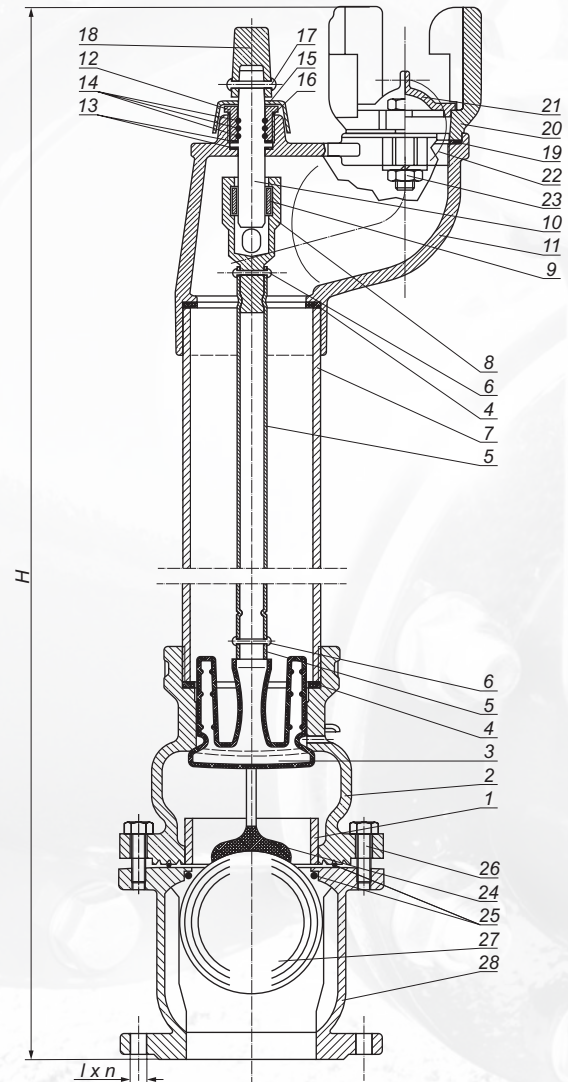

Underground hydrant double protected with a nominal diameter of 80 mm for pressure 1,0 or 1,6 MPa with an automatic drainage device in the lower chamber. Intended for drawing water from a general-purpose pipeline with a nominal diameter of 80 mm, water at a temperature of up to 40°C and a pressure of up to 1,0 or 1,6 MPa. Equipped with a ball protection.

Certificate of Conformity CNBOP 1438/CPR/0144

Coating: epoxy paint UV resisted, 250-360 μm
Flange connection: PN-EN 1092-2:1999
Nominal pressure: 1,0/1,6 MPa, PN 10/16

DN	Size	H	Rd	l	n	Weight
80	A	750	1000	18	8	30,00
	B	1000	1250	18	8	32,50
	C	1250	1500	18	8	35,00
	X	as per order				