

Street grate

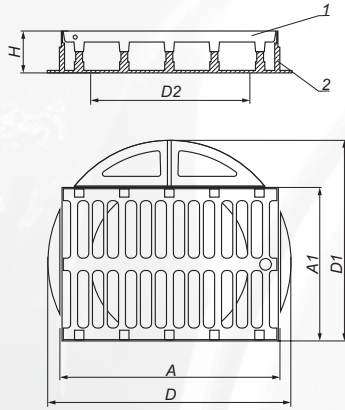

Grate BK 67

No.	Description	Material
1.	Lid	EN-GJL-250/ EN-GJS-500-7
2.	Body	EN-GJL-250/ EN-GJS-500-7

Coating: bitumen paint

Load	Class	A	A1	D	D1	D2	H	Weight
25 T	C 250	620	428	696	562	452	115	60,00/47,00
40 T	D 400	620	428	696	562	452	115	61,00/47,50

Norm: PN-EN 124-2

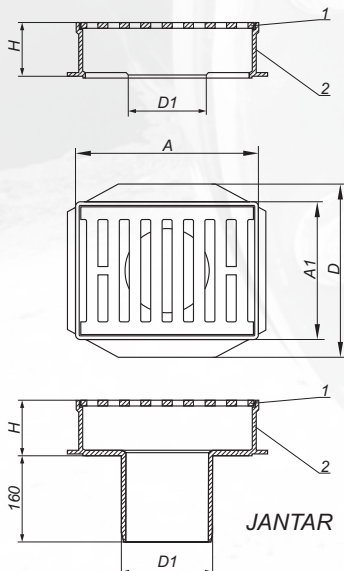

Grate BK 71

No.	Description	Material
1.	Lid	EN-GJL-250
2.	Body	EN-GJL-250

Coating: bitumen paint

Load	Class	A	A1	D	D1	H	Weight
1,5 T	A 15	320	225	255	150	80	19,00
1,5 T JANTAR	A 15	320	225	255	160	80	21,00

Norm: PN-EN 124-2

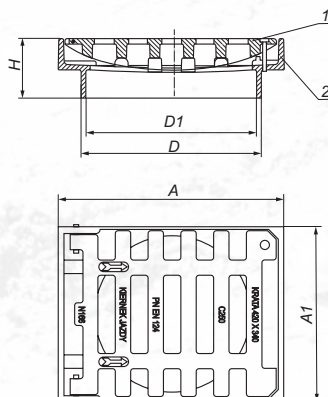

Grate BK 166

No.	Description	Material
1.	Lid*	EN-GJL-250
2.	Body	EN-GJL-250

* D 400 class - ductile iron EN-GJS-500-7, PN-EN 1563:2000.

Coating: bitumen paint

Load	Class	A	A1	D	D1	H	Weight
25 T	C 250	420	340	333	315	112	29,80
40 T	D 400	420	340	333	315	112	29,90

Norm: PN-EN 124-2