

## Telescope 315 with cover and grate

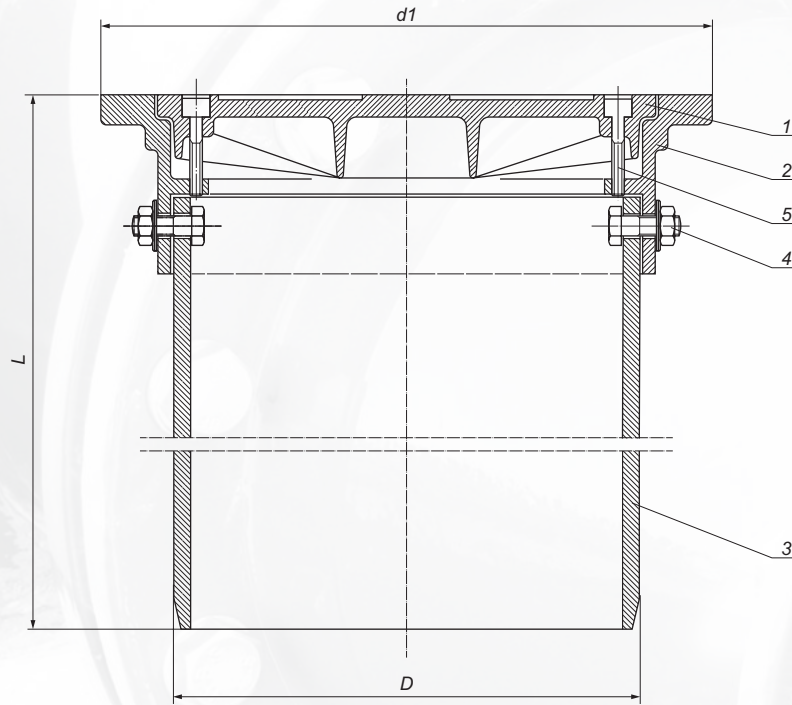

It is used as a top of inspection chamber size 315 and 400.  
The telescope is mounted on a rising pipe:  
corrugated 315, smooth 400, corrugated 400  
by the rubber adaptors:  
OW 315/315, GW 315/400, DW 315/400, WK 315/400.

No.	Description	Material
1.	Lid*	EN-GJL-250
2.	Body	EN-GJL-250
3.	Pipe	PVC 315
4.	Screw, pad, nut	Galvanized steel 8.8 class
5.	Allen screw	Galvanized steel 8.8 class/ Stainless steel A2

\* C 250, D 400 class - ductile iron EN-GJS-500-7, PN-EN 1563:2000.  
No. 1., 2. bitumen paint.

Lid type	Load	Class	D	L	d1	Weight
Cover	1,5 T	A 15	315	550	355	16,00
	12,5 T	B 125	315	550	355	23,00
	25 T	C 250	315	550	355	24,00
	40 T	D 400	315	550	355	24,00
Grate	1,5 T	A 15	315	550	355	15,50
	12,5 T	B 125	315	550	355	22,50
	25 T	C 250	315	550	355	23,50
	40 T	D 400	315	550	355	23,50

Different length can be made according to the order.  
B 125, C 250, D 400 class available also with round body.

Norm: PN-EN 124-2