

## Telescopic spindle for valves and spotting drills

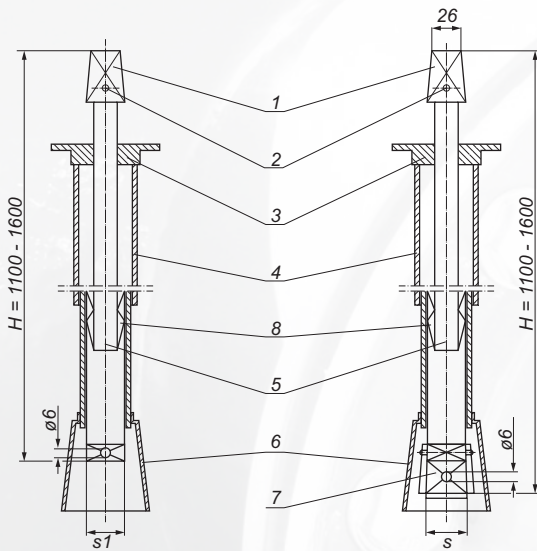

The spindle's length can be built in according to the order.  
Other dimensions „s” are according to the order.

Optionally can be made in galvanized version.

No.	Description	Material
1.	Upper cap	EN-GJL-250/EN-GJS-500-7
2.	Rivet	Steel
3.	Collar	HDPE
4.	Shield pipe	PE
5.	Telescopic rod	Steel/Galvanized steel
6.	Lower shield	HDPE
7.	Lower cap	EN-GJL-250/EN-GJS-500-7
8.	Locking clutch	St 2

Valve size (DN)	s	Lenght [mm]	Weight
20/25/32	12	1100-1600	3,50
20/25/32/40/50	14		3,70
65/80	17		3,70
100/125/150	19		3,70
200	24		4,70
250/300	27		6,70
350/400	32		7,50
PE valve	52	600-1100	2,80
Description	s1	Lenght [mm]	Weight
Telescopic spindle for spotting drill NS	14	1100-1600	3,20

## Fixed spindle for valves and spotting drills

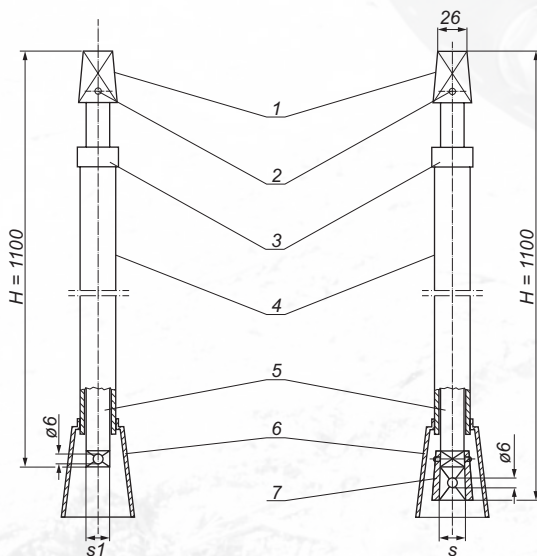

The spindle's length can be built in according to the order.  
Other dimensions „s” are according to the order.

Optionally can be made in galvanized version.

No.	Description	Material
1.	Upper cap	EN-GJL-250/EN-GJS-500-7
2.	Rivet	Steel
3.	Collar	HDPE
4.	Shield pipe	PE
5.	Rod	Steel/Galvanized steel
6.	Lower shield	HDPE
7.	Lower cap	EN-GJL-250/EN-GJS-500-7

Valve size (DN)	s	Lenght [mm]	Weight
20/25/32	12	1100	2,90
20/25/32/40/50	14		3,10
65/80	17		3,10
100/125/150	19		3,10
200	24		4,10
250/300	27		6,10
350/400	32		6,90
PE valve	52	600	2,40
Description	s1	Lenght [mm]	Weight
Fixed spindle for spotting drill NS	14	1100	2,70